

MOHAWK LIFTS MOBILE JACK STANDS

20,000, 30,000 OR 40,000 LB. CAPACITIES

Mohawk jack stands are available with rubber topped flat pads or optional axle engaging yoke pads

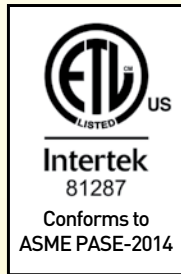
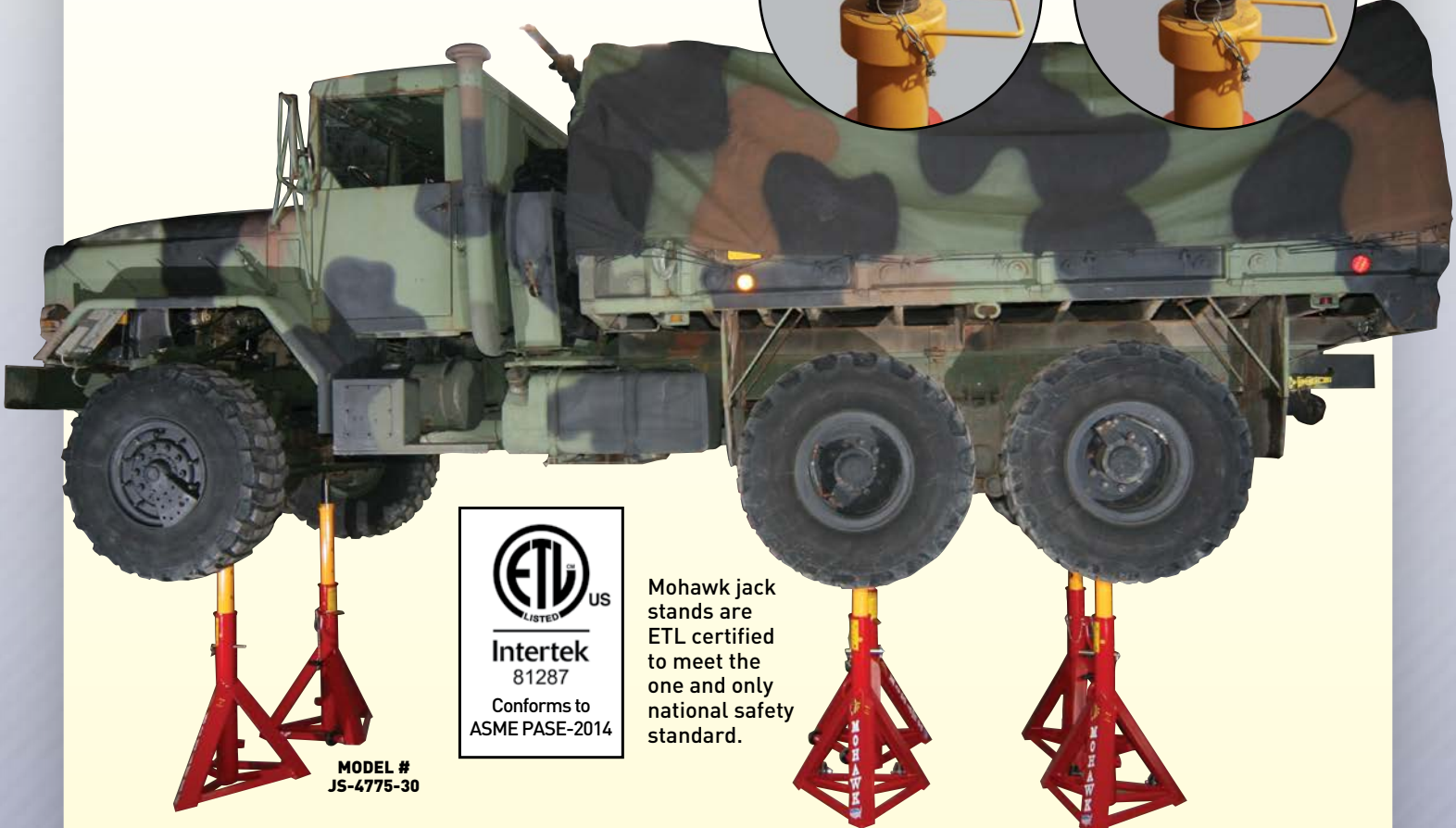
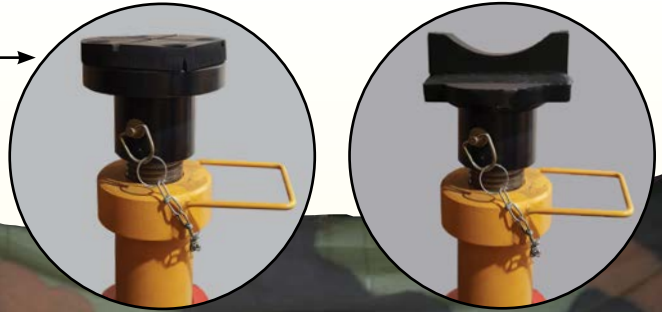

Mohawk jack stands are ETL certified to meet the one and only national safety standard.

MODEL # JS-4775-30

1 set of mobile columns



1 set of stands



2 vehicles in the air



Americas Best Lift Investment...

MOHAWK LIFTS

Still proudly designed, welded and manufactured in the U.S.A.



MOHAWK JACK STANDS



Mohawk jack stands are ETL certified to meet the one and only national safety standard.



Mohawk's mobile jack stands are equipped with a handle and large castors for easy movement



MODEL # JS-3047-20 20,000 lb

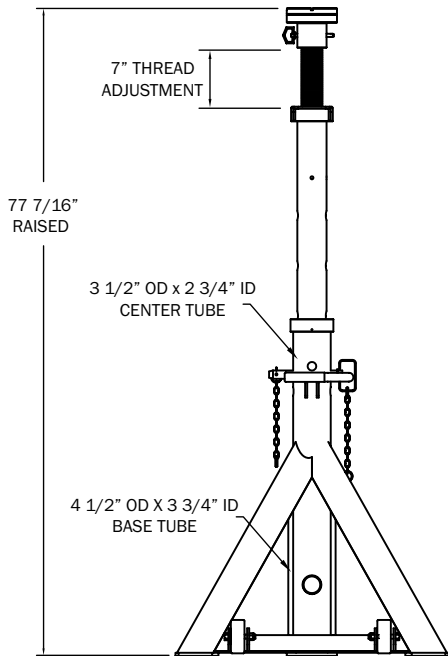

Model: JS-4775-20 20,000 lb

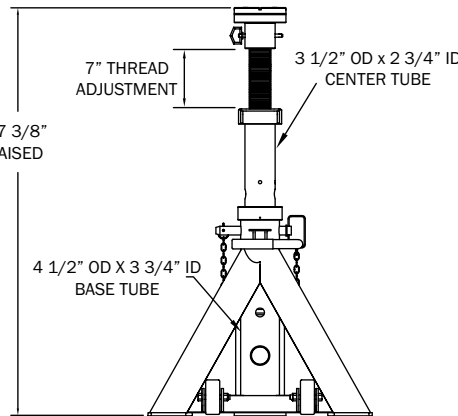

Model: JS-3047-20 20,000 lb

- A set of stands allows mobile columns to be moved to a different bay and raise another vehicle
- Adjustable height stands are available in 47–77" and 30–47" varieties
- Spring assisted inner tube allows technicians to easily raise and lower to proper heights

AUTOCAD specs available online at www.mohawklifts.com/specs

MOHAWK LIFTS

Mohawk Lifts, LLC.
 P.O. Box 110
 65 Vrooman Ave
 Amsterdam, NY 12010
 (800) 833-2006
 (518) 842-1431
 FAX: (518) 842-1289
www.mohawklifts.com

AVAILABLE UNDER DISCOUNTED GOVERNMENT CONTRACT IN ALL 50 STATES



DISTRIBUTED BY: