

MODEL LMF-12-3SA

12,000 LB. CLEAR FLOOR 2 POST LIFT

**THE LIFT YOU CAN'T
WEAR OUT**

25
YEAR
WARRANTY



**Includes 3 stage swing
arms standard, for all of
your lifting needs!**

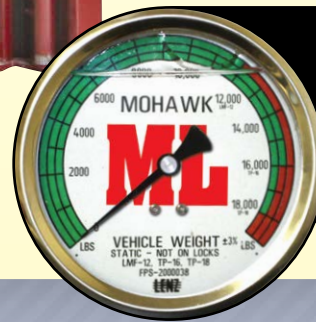

Safety Weight Gauge
Shows vehicle weight, aids
vehicle diagnosis, visually
shows when lift is lowered
on the locks

MOHAWK LIFTS

Americas Best Lift Investment...

Still proudly designed, welded
and manufactured in the U.S.A.



MODEL LMF-12-3SA

SOLID, SAFE, PROVEN & CERTIFIED HEAVY DUTY LIFTS FOR... HEAVY DUTY SERVICE

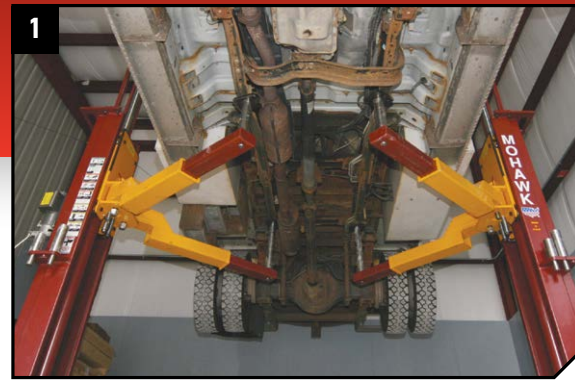

▲ Two post lifts offer **FULL unobstructed under vehicle access** for all repairs, take up minimal bay space and leaves wheels hanging free for tire, brake or any other necessary repairs.

MOHAWK DESIGN

- Mohawk columns are constructed of $\frac{3}{4}$ " thick forklift masts, for a **lifetime** of trouble-free service.
- Each Mohawk carriage rolls on 8 double-sealed, self-lubricating, steel **ball bearing rollers** (NOT plastic sliders).
- Two 4" heavy duty cylinders make for safer, steadier lifting than single cylinder lifts or models with tiny cylinders.
- Easily **adjustable** overhead stainless steel hydraulic lines can be set at **any** height (or routed in floor) to accommodate all tall trucks and vans.
- **Low profile 5"** swing arms fit under most passenger cars.
- Equipped with Mohawk's 5", 7 $\frac{1}{2}$ " and 10" stackable lift adaptor pads.
- 60 second lifting speed saves shops time and money.
- Standard with three stage swing arms that can reach the furthest lifting points.



LIFT SHOWN WITH IN-FLOOR HYDRAULIC LINES

Mohawk lifts **DO NOT** use height restrictive overhead cable covers that limit lifting height.

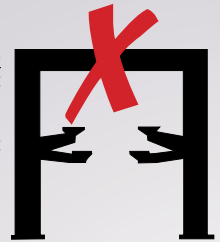

Includes: ▶
5", 7 $\frac{1}{2}$ " and 10"
stacking adaptors (for
hard to reach frames)



MOHAWK PATENTED INDUSTRY LEADING SAFETY SYSTEMS

- Mohawk lifts feature **all position** mechanical safety locks in both columns, starting at the ground, to full lifting height.
- Patented, infinite position, internal hydraulic safeties backed by external pressure compensated flow controls and velocity fuse valving.
- Swing arm restraints automatically engage upon lifting and automatically disengage when the vehicle has been fully lowered.
- Lease/purchase plans available for 1-5 years.
Call Mohawk now!

- The best, and most inclusive warranty in the lift business; 25 years structural, 10 year mechanical, plus limited lifetime cylinder seal warranty. **Mohawk builds the best lifts, with the best warranty.**

OPERATION

- Hydraulic fluid is pumped between the two cylinders through the overhead (or optional in-floor) stainless steel hydraulic lines. Patented hydraulic synchronization eliminates the need for restrictive height overhead covers, cables, pulleys, equalizer chains or obstructive floor plates.
- To raise the carriages, Mohawk's LMF-12-3SA uses direct



2 ▲ Mohawk's large and stable footprint measures 30" wide by 24" is made of 3/4" thick plate. Mohawk's large base gives stability to the lift, while distributing the load to the shop floor.

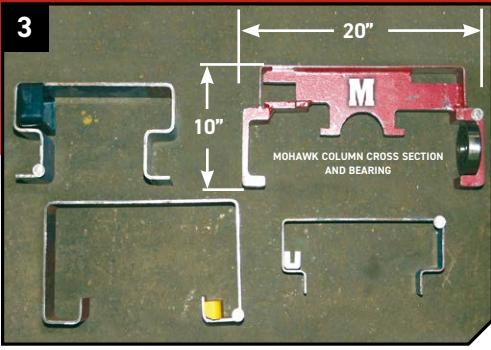

3 ▲ Mohawk's fork lift channel & bearing (top right) VS. 3 different sheet metal columns which use plastic slides. Like your fork lifts mast, **Mohawk Lifts DO NOT WEAR OUT!**

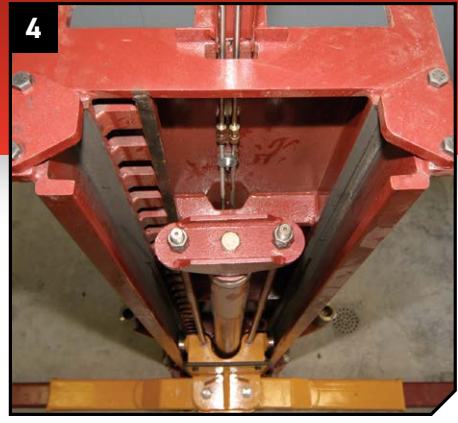

4 ▲ Heavy duty column construction with direct drive cylinders, direct drive lifting rods (not cables) and stainless steel hydraulic lines (not rubber hoses) which will never wear.

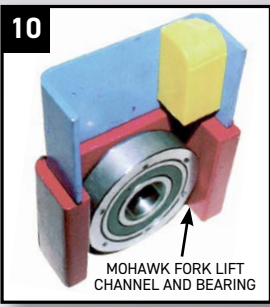

10 ▲ **FORK LIFT CHANNEL & bearing** (bottom) vs. competitive columns & plastic slider (top)

INCLUDES 3 STAGE SWING ARMS STANDARD



ADJUSTABLE HEIGHT STAINLESS STEEL hydraulic lines

SHOWN WITH OPTIONAL ADJUSTABLE SCREW PADS



9 ▲ **LARGE 4" CYLINDERS** equal longer seal life and lower operating pressures vs. smaller competitive cylinders.



5 ▲ Each carriage rolls on (8) 4" double sealed, self lubricating, heavy duty ball bearing rollers for a lifetime of trouble-free service (not plastic slide blocks).

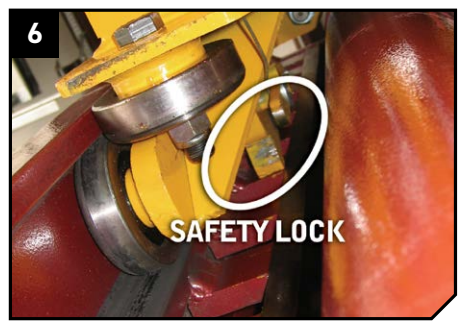

6 ▲ ALL position 1" thick mechanical locks on BOTH carriages engage the full length of travel. Available with optional single point air lock release (requires air to lift).



LIFT SHOWN WITH OPTIONAL SPEEDLANE ADAPTORS, WINNER OF MOTOR MAGAZINE TOP 20 TOOLS

drive lifting rods which eliminate the wear & maintenance associated with lifts that use cables, chains, & overhead cable covers.

- Mohawk carriages roll on eight double sealed, self-lubricating, steel ball bearing rollers, for a lifetime of maintenance-free operation.
- Mohawk bearings last longer, with less friction and wear than competitive lifts using plastic slide blocks which need constant greasing and maintenance.

What other lift offers a 25 year structural warranty?

2 POST ACCESSORIES



Safety Weight Gauge
to determine vehicle weight, aid vehicle diagnosis & show lift is lowered onto locks.

Speedlane Adaptor
Slips on quickly for instant lifting without positioning swing arms yet leaves the wheels hanging free for tire and brake work.

MODEL LMF-12-3SA SPECIFICATIONS

Model:	LMF-12-3SA
Capacity:	12,000 lbs. (5443.11 Kg)
Lifting Speed:	60 seconds (faster with lighter load)
Motor Rating:	4 HP/208-230V, Single-phase (3ø optional)
Synchronization:	Hydraulic fluid displacement using no chains, cables, or overhead obstructions
Arm Pad Height:	5" (12.7 cm) min.
Lifting Height:	6' (1.83 m) under arm
Arm Pad Height @ Full Rise:	6'5" (1.96 m)
Max. Arm Pad Height with Adaptors:	7'3" (2.21 m)
Overall Width:	12' 7½" (3.85 m) (adjustable)
Width Between Posts:	10' (3.05 m) (adjustable)
Width Between Lifting Arms:	8' 9¾" (2.69 m) (adjustable)
Column Height:	8' 7" (2.62 m)
Max. Cylinder Height:	13'6" (4.11 m)
Overhead Hydraulic Line Height:	15' (4.57 m) Standard (adjustable to accommodate any height ceiling or routed in-floor)
Weight:	LMF-12: 3100 lbs. (1406.13 Kg)
Concrete Floor Requirements:	4000 psi (27579.02 kPa) mix 6½" (16.51 cm) depth
Anchoring System: Included	(16) ¾"x6" (1.91x15.24 cm) bolts
Mechanical Safety Locks:	Automatic; multi-position starting @ 5" (12.7 cm) off the floor
Hydraulic Safety Systems:	Automatic; all position
Swing Arm Restraints:	Automatic upon ascent
Cylinders:	2 (1 per column)
Drive System:	Direct drive (using no cables or chains)
5" Frame Adaptors (stackable):	4 included as standard equipment
7½" Frame Adaptors (stackable):	4 included as standard equipment
10" Frame Adaptors (stackable):	4 included as standard equipment
Steel Carriage Bearings:	(16) 4" (10.16 cm) diameter (8 per carriage) double sealed, self-lubricating ball bearing rollers
Floor Access Between Posts:	Clear and unobstructed
Warranty:	25 years structural, 10 year mechanical, plus limited lifetime cylinder seal warranty

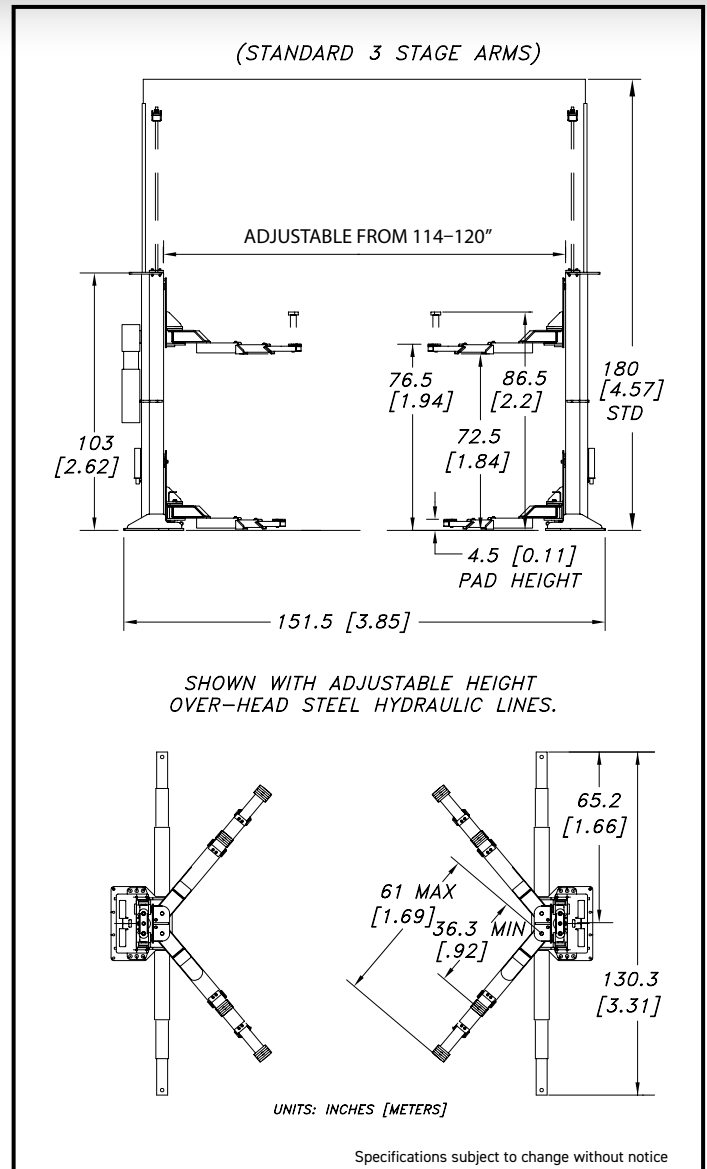

Mohawk builds the best products with the finest materials, to the highest standards. Just compare our lifts. Our staff will assist you with a fleet evaluation, design assistance and answer any technical questions you have. We invite your calls.

Mohawk lifts are manufactured in compliance with the following standards: ALI, ANSI, ASME, AISI, ASTM, ASA, NEC, AWG, NEMA.

MEETS CURRENT NATIONAL ANSI (ANSI/ALI ALCTV) CODE FOR LIFTS.



For more detailed product information read this book at www.mohawklifts.com/wmamam



www.facebook.com/mohawklifts

MOHAWK LIFTS

Mohawk Lifts, LLC.
P.O. Box 110
65 Vrooman Ave
Amsterdam, NY 12010
(800) 833-2006
(518) 842-1431
FAX: (518) 842-1289
www.mohawklifts.com

AVAILABLE UNDER DISCOUNTED GOVERNMENT CONTRACT IN ALL 50 STATES



DISTRIBUTED BY: