

LIFTPOINT.

LTX-18/LTX-22/LTX-30

18,000, 22,000 & 30,000 LB. MATERIAL HANDLING SERVICE LIFTS

"What once took us 2 hours on the floor now takes 8 minutes standing."

*Material Handling Technician
Fortune 100 CPG Company*



TO MEET THE ONE AND ONLY ANSI STANDARD FOR SERVICE LIFTS

**MODEL LTX-18
MHX18**



READER'S CHOICE • PRODUCTS OF THE YEAR

2023

MATERIAL HANDLING PRODUCT NEWS MATERIAL HANDLING 247

WINNER

25
YEAR
WARRANTY

**THE ONLY LIFT DESIGNED TO SERVICE
FORKLIFTS, PALLET JACKS, REACH
TRUCKS, ORDER PICKERS & MORE**

- Speeds Repairs & Boosts Fleet Reliability
- Improves "PM" Compliance
- Reduces Parts Expenses
- Reduces Injuries & Improves Ergonomics
- Reduces Workman's Comp Exposure

UPTIME. SAFETY. DEPENDABILITY. RESULTS.

MODELS LTX-18/LTX-22/LTX-30

SOLID, SAFE & PROVEN HEAVY DUTY LIFTS FOR... HEAVY DUTY SERVICE



▲ The LTX offers **FULL unobstructed underside access** for material handling equipment for all repairs, takes up minimal bay space and leaves wheels hanging free for tire, brake or any other necessary repairs.

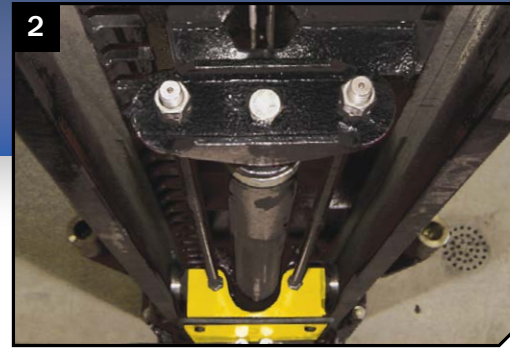

▲ Heavy duty column construction with direct drive cylinders, direct drive lifting rods and stainless steel hydraulic lines are built for decades of low-maintenance operation.



▲ LiftPoint's **large and stable footprint** measures 30" wide by 24" and is made of 1/4" thick plate. LiftPoint's large base gives stability to the lift, while distributing the load to the shop floor.

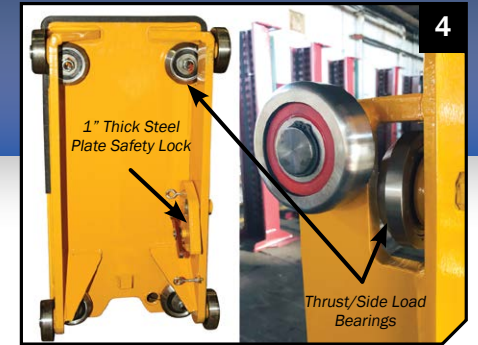

▲ LiftPoint's welded steel carriages roll on eight double sealed, self-lubricating, steel ball bearing rollers, and incorporates a thrust load bearing design to dissipate the thrust from heavy counterbalanced forklifts.

LIFTPOINT DESIGN

- LiftPoint columns are constructed of 3/4" thick forklift masts, for a lifetime of trouble-free service and reliability.
- Each LiftPoint carriage rolls on 8 double-sealed, self-lubricating, steel ball bearing rollers.
- Two 4" heavy duty cylinders (one in each post) make for a safe and stable lift.
- Low profile (1.5") three stage swing arms fit under most material handling equipment (lower profile adapters available).
- Adjustable three stage arms ensure compatibility with fleets of various model types, lengths and widths.
- Easily adjustable overhead stainless steel hydraulic lines can be set at any height (or routed in floor) to accommodate even the tallest masts.



The inspiration behind the design of the LTX Series is a forklift's mast which provides a degree of stability and reliability that other lifts cannot.

LTX-18 SHOWN WITH RAYMOND REACH TRUCK WITH 12' MAST



ALL position 1" thick mechanical locks on BOTH carriages engage the full length of travel. Available with optional single point air lock release, requires air to lift.

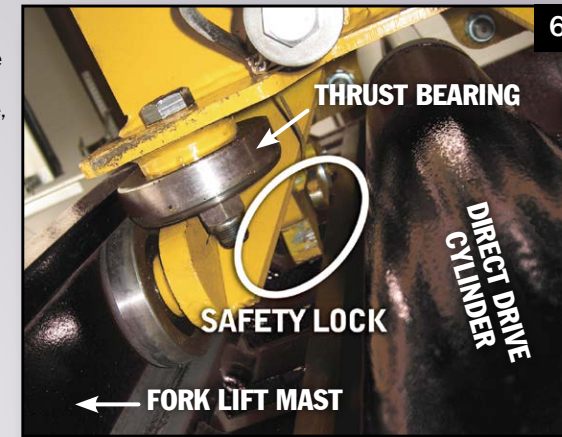

THE LTX LEVERAGES FORKLIFT MAST/ "L" CHANNEL ROLLED STEEL & SEALED ROLLER BEARINGS... JUST LIKE THE EQUIPMENT IN YOUR MATERIAL HANDLING FLEET.

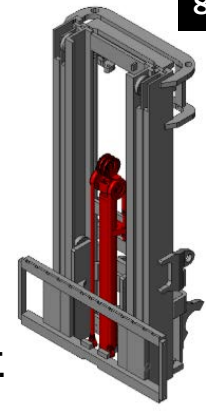

GET YOUR TECHS OFF THE GROUND



LIFTPOINT PATENTED INDUSTRY LEADING SAFETY SYSTEMS

- Patented, infinite-position, internal hydraulic safeties backed by external pressure compensated flow controls and velocity fuse valving.
- LiftPoint lifts feature **all position** mechanical safety locks in both columns, starting at the ground, to full lifting height.
- Swing arm restraints automatically engage upon lifting and automatically disengage when the material handling equipment has been fully lowered.
- Electric safeties prohibit overloading of system.

- The best, and most inclusive warranty in the business; 25 years structural, 10 year mechanical, plus limited lifetime cylinder seal warranty.

OPERATION

- Hydraulic fluid is pumped between the two cylinders through the overhead (or optional in-floor) stainless steel hydraulic lines.
- Patented hydraulic synchronization system ensures even lifting and eliminates the need for restrictive height overhead covers, cables, pulleys, equalizer chains or obstructive floor plates.

- To raise the carriages, the LTX Series uses a true piston and ram system, direct drive lifting rods and high quality U.S. power systems for smooth, stable lifting (pic #2).
- LiftPoint's welded steel carriages roll on eight double sealed, self-lubricating, steel ball bearing rollers, and incorporates a thrust load bearing design to dissipate the thrust from heavy counterbalanced forklifts (pic #4).
- LiftPoint bearings last longer, with less friction and wear than competitive lifts using plastic slide blocks which need constant greasing and maintenance.

What other lift offers a 25 year structural warranty?

13,000 INJURIES

Each year, technicians experience over 13,000 non-fatal "lost-time incidents" at work. The majority of these are due to chronic injuries, leading to more sprains, strains, and tears.

These injuries increase in frequency with age & on tasks with poor ergonomics.

LIFTPOINT LTX-18/LTX-22/LTX-30

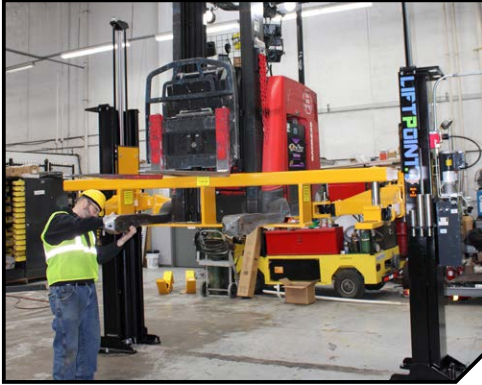

Optional Outrigger and Mast Adapter

Drive-thru adapters enable lifting from pallet jack forks, outriggers or under the mast.



Get Your Techs Off The Ground

Total Underside Access Allows Techs to Service Components Without Getting On Hands & Knees.



Optional TD-350 Tire Jack

Enables Techs to Safely Remove Tires for Wheel & Brake Service

Model:	LTX-18/LTX-22
Capacity:	18,000/22,000 lbs.
Motor Rating:	4 HP/208-230V, Single-phase (3Ø optional)
Synchronization:	Hydraulic fluid displacement using no chains, cables, or overhead obstructions
Arm Pad Height:	1½" min.
Lifting Height:	6' under arm
Overall Width (adjustable):	12' 7½"
Weight:	3,200 – 3,800 lbs.
Concrete Floor Requirements:	Wide Base: 5½" of 4,000 psi concrete Standard Base: 6½" of 4,000 psi concrete
Anchoring System: Included	(16) ¾"x6" bolts
Mechanical Safety Locks:	Automatic; multi-position starting @ 5" off the floor
Hydraulic Safety Systems:	Automatic; infinite-position
Swing Arm Restraints:	Automatic upon ascent
Cylinders:	2 (1 per column)
Drive System:	Direct drive (using no cables or chains)
Lifting Speed:	60 seconds (faster with lighter load)
Thrust & Guide Bearings:	(16) 4" diameter, (8 per carriage) double sealed, self-lubricating ball bearing rollers
Floor Access Between Posts:	Clear and unobstructed
Warranty:	25 years structural

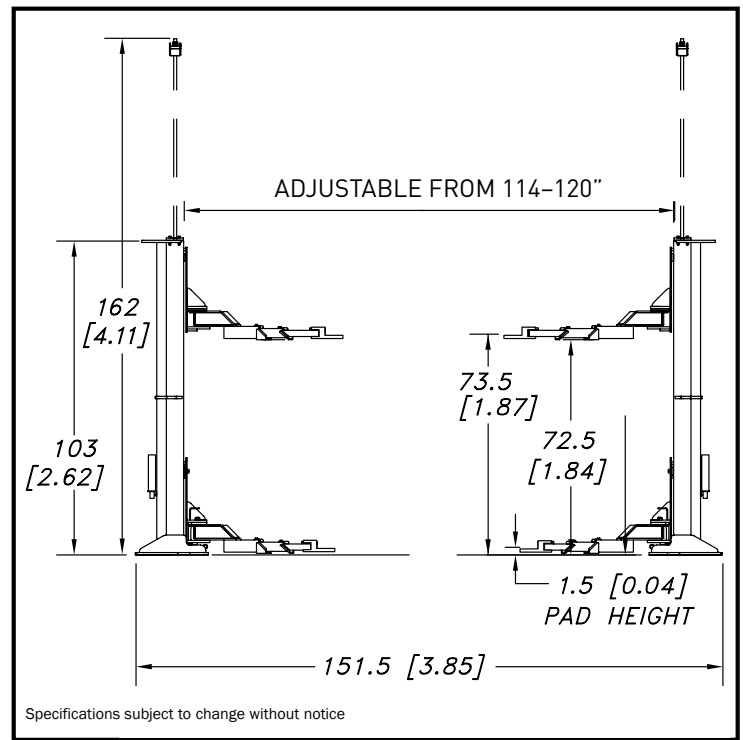

*Please note: LTX-22 is only available as a wide base model

**Please note: LTX-30 specifications available upon request

LIFTPOINT.
A Division of Mohawk Lifts, LLC.

P.O. Box 110
65 Vrooman Ave
Amsterdam, NY 12010
(800) 833-2006
(518) 842-1431
FAX: (518) 842-1289
www.LiftPointUSA.com

DISTRIBUTED BY: