

# MODEL ML-220XL

20,000 LB. CLEAR FLOOR 2 POST LIFT

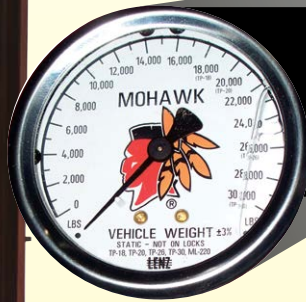

TO MEET THE ONE AND ONLY NATIONAL SAFETY STANDARD FOR VEHICLE LIFTS



**Safety Weight Gauge**  
Shows vehicle weight, aids vehicle diagnosis, visually shows when lift is lowered on the locks

**25**  
YEAR  
WARRANTY

**THE LIFT YOU  
CAN'T WEAR OUT**

*Americas Best Lift Investment...*

**MOHAWK LIFTS**

Still proudly designed, welded and manufactured in the U.S.A.



# MODEL ML-220XL

## SOLID, SAFE & PROVEN HEAVY DUTY LIFTS FOR... HEAVY DUTY SERVICE



▲ Two post lifts offer **FULL unobstructed under vehicle access** for all repairs, take up minimal bay space and leaves wheels hanging free for tire, brake or any other necessary repairs.

### MOHAWK DESIGN

- Mohawk columns are constructed of  $\frac{3}{4}$ " thick forklift masts, for a **lifetime** of trouble-free service.
- Each Mohawk carriage rolls on 8 double-sealed, self-lubricating, steel **ball bearing rollers** (NOT plastic sliders).
- Two 4" heavy duty cylinders make for safer, steadier lifting than single cylinder lifts or models with tiny cylinders.
- Easily **adjustable** overhead stainless steel hydraulic lines can be set at **any** height (or routed in floor) to accommodate all tall trucks and vans.
- 4.5" (lowered height) extra long, three stage swing arms fit under most all passenger cars & trucks.
- Equipped with 3" and 6" stacking adaptors with a spin-up adjustable pad for precise level lifting.
- Standard with three stage swing arms that can reach the furthest lifting points.



Mohawk lifts **DO NOT** use height restrictive overhead cable covers that limit lifting height.



▲ **RUSTPROOF ALUMINUM ADAPTORS**, 3" and 6" locking stackable adaptors with a spin-up adjustable pad for precise level lifting

### OPERATION

- Hydraulic fluid is pumped between the two cylinders through the stainless steel hydraulic lines. Patented hydraulic synchronization eliminates the need for restrictive height overhead covers, cables, pulleys or equalizer chains.
- To raise the carriages, Mohawk's ML-220XL uses direct drive lifting rods which eliminate the wear & maintenance associated with lifts that use cables and chains.
- Mohawk carriages roll on 8 double sealed, self-lubricating, steel ball bearing rollers, for maintenance-free operation.
- Mohawk bearings eliminate constant friction and wear. Competitive lifts use plastic slide blocks that wear out.

### MOHAWK PATENTED INDUSTRY LEADING SAFETY SYSTEMS

- Mohawk lifts feature **all position** mechanical safety locks in both columns, starting at the ground, to full lifting height.
- Patented, infinite position, internal hydraulic safeties backed by external pressure compensated flow controls and velocity fuse valving.
- Swing arm restraints automatically engage upon lifting and automatically disengage when the vehicle has been fully lowered.



**2** ▲ Mohawk's **large and stable footprint** measures 30" wide by 24" is made of 3/4" thick plate. Mohawk's large base gives stability to the lift, while distributing the load to the shop floor.

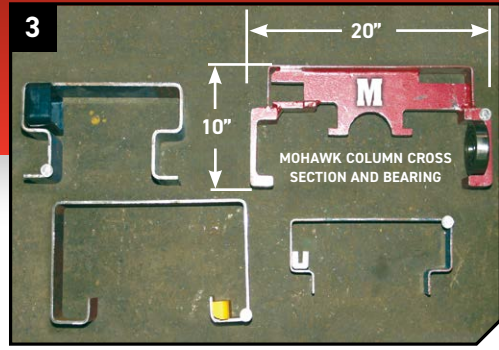

**3** ▲ Mohawk's fork lift channel & bearing (top right) VS. 3 different sheet metal columns which use plastic slides. Like your fork lifts mast, **Mohawk Lifts DO NOT WEAR OUT!**

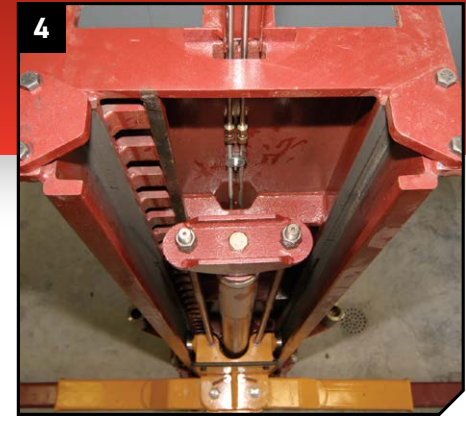

**4** ▲ **Heavy duty column construction** with direct drive cylinders, direct drive lifting rods (not cables) and stainless steel hydraulic lines (not rubber hoses) which will never wear.

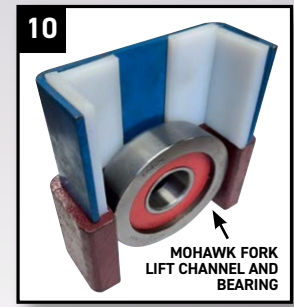

**10** ▲ **FORK LIFT CHANNEL** & bearing (bottom) vs. competitive columns & plastic slider (top).

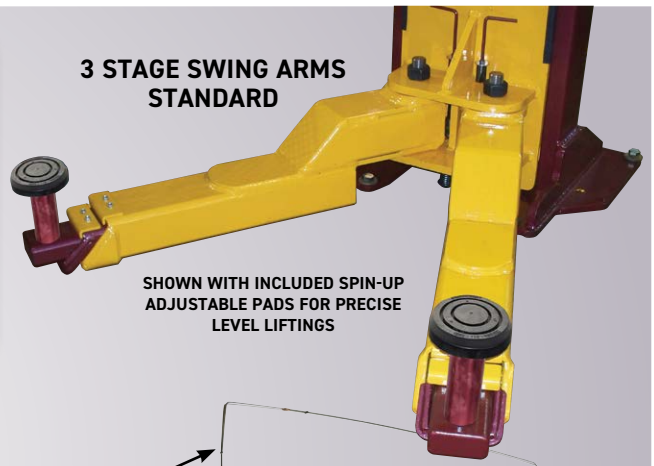

**3 STAGE SWING ARMS STANDARD**  
SHOWN WITH INCLUDED SPIN-UP ADJUSTABLE PADS FOR PRECISE LEVEL LIFTINGS  
ADJUSTABLE HEIGHT STAINLESS STEEL HYDRAULIC LINES



**5** ▲ Each carriage rolls on (8) 4" double sealed, self lubricating, heavy duty ball bearing rollers for a **lifetime of trouble-free service** (not plastic slide blocks).



**9** ▲ **LARGE 4" CYLINDERS** equal longer seal life and lower operating pressures vs. smaller competitive cylinders.

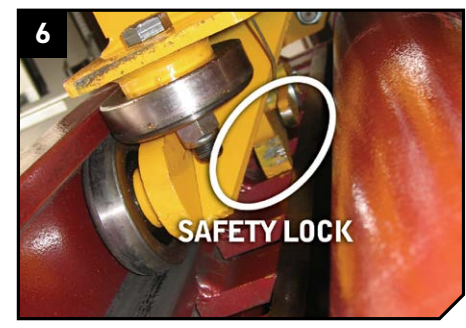

**6** ▲ **ALL position 1" thick mechanical locks** on **BOTH** carriages engage the full length of travel. Available with optional single point air lock release (requires air to lift).

## WHY MOHAWK

- Mohawk lifts feature **all position** mechanical safety locks in both columns, starting at the ground, to full lifting height.
- The best, and most inclusive warranty in the lift business; 25 years structural, 10 year mechanical, plus limited lifetime cylinder seal warranty.

**Mohawk Builds the Best Lifts,  
With the Best Warranty.**

## 2 POST ACCESSORIES



**Safety Weight Gauge**  
to determine vehicle weight, aid vehicle diagnosis & show lift is lowered onto locks.

**Speedlane Adaptor**  
Slips on quickly for instant lifting without positioning swing arms yet leaves the wheels hanging free for tire and brake work.

# MODEL ML-220XL SPECIFICATIONS

<b>Model:</b> .....	<b>ML-220XL</b>
<b>Capacity:</b> .....	20,000 lbs.
<b>Motor Rating:</b> .....	4 HP/208-230V, Single-phase (3ø optional)
<b>Synchronization:</b> .....	Direct drive hydraulic fluid displacement using no chains, cables, or overhead obstructions
<b>Arm Pad Height:</b> .....	5' 11 1/16" min.
<b>Lifting Height (stroke):</b> .....	73" (6') under arm
<b>Arm Pad Height @ Full Rise:</b> .....	7' 2 1/4" (86.2")
<b>Overall Width:</b> .....	12' 7 1/2" (151.5") <b>adjustable</b>
<b>Width Between Posts:</b> .....	Adjustable 9' 6" to 10' (114" to 120")
<b>Width Between Lifting Arms:</b> .....	103.81" <b>adjustable</b>
<b>Column Height:</b> .....	10' (120")
<b>Max. Cylinder Height:</b> .....	13' 6" (162")
<b>Overhead Hydraulic Line Height:</b> .....	15' (180") Standard ( <b>adjustable</b> to accommodate any height ceiling or routed in-floor)
<b>Weight:</b> .....	4,100 lbs.
<b>Concrete Floor Requirements:</b> .....	<b>Standard Base:</b> 6 1/2" of 4,000 psi concrete <b>Wide Base:</b> 5 1/2" of 4,000 psi concrete
<b>Anchoring System: Included</b> .....	(16) 3/4" x 6" bolts
<b>Mechanical Safety Locks:</b> .....	<b>Automatic;</b> multi-position starting @ 5" off the floor
<b>Hydraulic Safety Systems:</b> .....	<b>Automatic;</b> all position
<b>Swing Arm Restraints:</b> .....	<b>Automatic</b> upon ascent
<b>Cylinders:</b> .....	2 (1 per column)
<b>Drive System:</b> .....	Direct drive (using no cables or chains)
<b>Lifting Speed:</b> .....	90 seconds (faster with lighter load)
<b>3" Frame Adaptors (stackable):</b> .....	4 included as standard equipment
<b>6" Frame Adaptors (stackable):</b> .....	4 included as standard equipment
<b>Spin-Up Adjustable Pad:</b> .....	4 included as standard equipment
<b>Steel Carriage Bearings:</b> .....	(16) 4" diameter (8 per carriage) double sealed, self-lubricating ball bearing rollers
<b>Floor Access Between Posts:</b> .....	Clear and unobstructed
<b>Warranty:</b> .....	<b>25 years structural, 10 year mechanical, plus limited lifetime cylinder seal warranty</b>

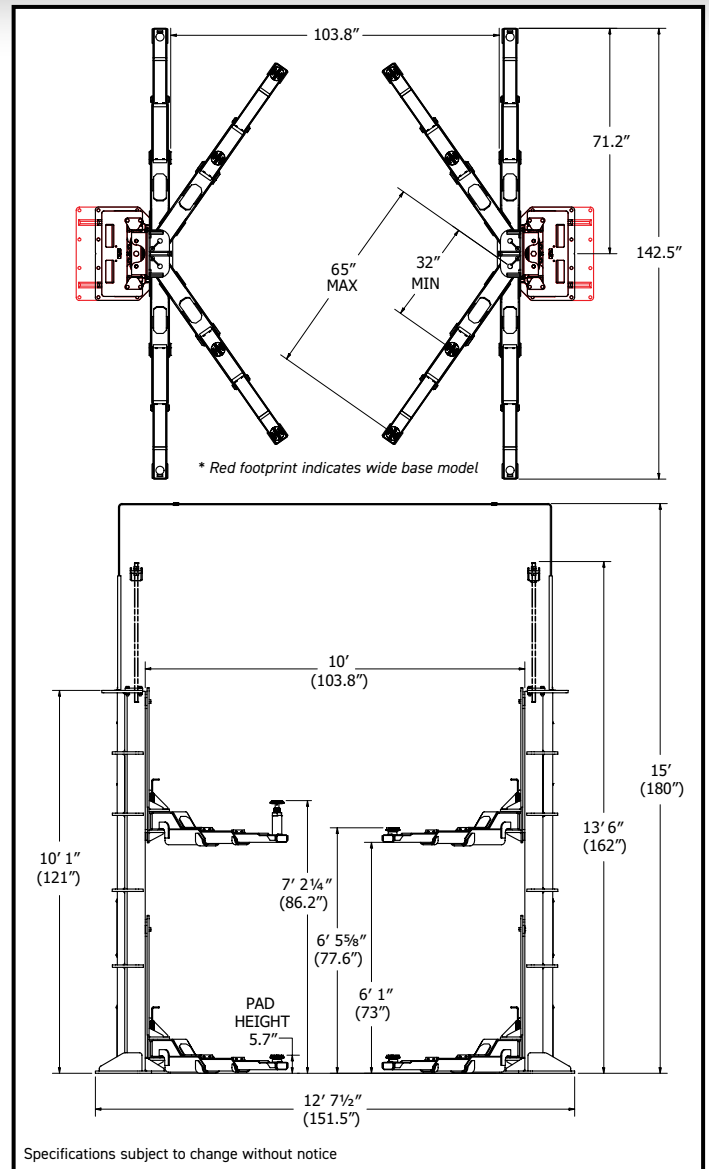

Scan the QR code to learn how Mohawk's two post vehicle lifts compare to the competition. [mohawklifts.com/dare2compare](http://mohawklifts.com/dare2compare)

## MOHAWK LIFTS

Mohawk Lifts, LLC.  
P.O. Box 110  
65 Vrooman Ave  
Amsterdam, NY 12010  
(800) 833-2006  
(518) 842-1431  
FAX: (518) 842-1289  
[www.mohawklifts.com](http://www.mohawklifts.com)

AVAILABLE UNDER DISCOUNTED GOVERNMENT CONTRACT IN ALL 50 STATES



DISTRIBUTED BY: