

MODEL TD-1000AH

AIR / HYDRAULIC • HIGH RISE • SIDE SHIFTING • TIRE DOLLY



**FOR FASTER,
SAFER & EASIER
HANDLING OF ALL
HEAVY DUTY TIRES**

FOR USE WITH ALL SINGLE & DUAL TRUCK TIRES

- 1000lb. or 2000lb. lifting capacities for the heaviest tires
- Use with any lift or any time heavy-duty truck tires must be removed
- Full 45" lifting height
- 6" side shifting ability makes alignment of wheels to lug holes easier
- Heavy-duty conveyor type rollers on lifting arms aid in realignment of bolt pattern
- When fully loaded, heavy duty 4" steel ball bearing casters allow easy movement
- Two rear 360 degree swivel casters are equipped with caster locks
- Tilting lift arms aid hub realignment and provide additional stability to the fully loaded dolly
- Safety chain provided to secure loads
- Foot pump allows for easy hands free operation making tire removal and replacement a one man job
- Ideal for placing tires on heavy duty wheel balancers
- Counterbalanced models available for parallelograms
- Foot operated air/hydraulic power unit
- Fully assembled & ready to use

MOHAWK LIFTS

Americas Best Lift Investment...

Still proudly designed, welded
and manufactured in the U.S.A.



MODEL TD-1000AH



Air / Hydraulic Foot Pump

SPECIFICATIONS:

Capacity:	1000 lbs.
Lifting Height (B):	45 1/4"
Overall Width (E):	44 3/4"
Overall Length:	44 3/4"
Overall Unit Height (C):	69 3/4"
Width of Lifting Arms (F):	24"
Arm Conveyor Length (I):	19 3/4"
Side Shifting Adjustment:	3" Left or Right
Max. Arm Tilt Angle:	13°
Min. Support Leg Clearance (D):	6"
Min. Arm Elevation:	3"
Air Operation:	Foot Control Up & Down
Casters:	4" Ball Bearing Type with Locking Rear 360° Rotation
Shipping Weight:	474 lbs.

* Specifications subject to change without notice

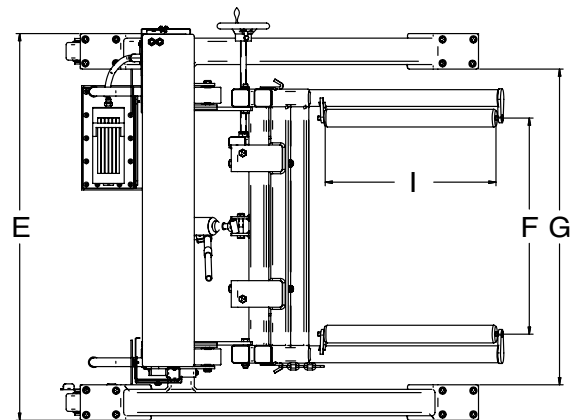
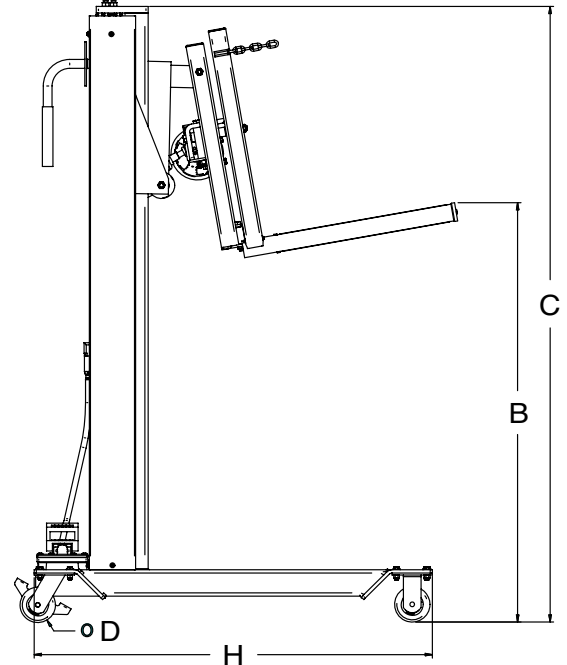

DIMENSIONS:

A = 2 1/8"	F = 24 1/2"
B = 45 1/4"	G = 35 3/4"
C = 69 3/4"	H = 41"
D = 4"	I = 19 3/4"
E = 43 3/4"	

AUTOCAD specs available online at www.mohawklifts.com/specs

MOHAWK LIFTS

Mohawk Lifts, LLC.
P.O. Box 110
65 Vrooman Ave
Amsterdam, NY 12010
(800) 833-2006
(518) 842-1431
FAX: (518) 842-1289
www.mohawklifts.com

AVAILABLE UNDER DISCOUNTED GOVERNMENT
CONTRACT IN ALL 50 STATES



DISTRIBUTED BY: