

\* SHOWN WITH 30' RUNWAYS.

\*\* POWER UNIT LOCATION PER CUSTOMER'S SPECIFICATION.  
SHOWN ABOVE IN STANDARD LOCATION.

**NOTICE OF CONFIDENTIAL INFORMATION**

INFORMATION CONTAINED HEREIN IS CONFIDENTIAL AND PROPERTY OF MOHAWK RESOURCES LTD. WHERE DRAWING IS FURNISHED TO OTHERS IT SHALL BE USED SOLELY FOR PURPOSES OF INSPECTION, INSTALLATION, OR MAINTENANCE. THE INFORMATION SHALL NOT BE USED OR DISCLOSED BY THE RECIPIENT FOR ANY OTHER PURPOSES WHATSOEVER.

REV.	DESCRIPTION	DATE	BY	APP'D.
△				

**SPECIFICATIONS:**

CAPACITY -----	35,000 LB
LIFTING SPEED -----	120 SECONDS
MOTOR RATING -----	10 HP, 208-230 VAC THREE PHASE
LIFTING MECHANISM -----	(4) 4" HYDRAULIC CYLINDERS, DIRECT DRIVE
OVERALL LENGTH -----	41'-11 11/16"
OVERALL WIDTH -----	14'-5 9/16"
LIFTING STROKE -----	5'
TRACK WIDTH -----	24"
CLEARANCE BETWEEN POSTS -----	11'-8"
MECHANICAL SAFETY RELEASE -----	SINGLE POINT
MECHANICAL SAFETY LOCKS -----	MULTI-POSITION
BACK-UP HYDRAULIC SAFETY SYSTEMS -----	P.C. FLOW CONTROLS & VELOCITY FUSES
WEIGHT -----	22000 LB
SYNCHRONIZATION (MAIN TO OFFSIDE) -----	(4) #646 LEAF CHAINS
SYNCHRONIZATION (FORE TO AFT) -----	ELECTRICALLY AUTOMATIC / MANUALLY ADJUSTABLE
FLOOR REQUIREMENTS -----	4000 PSI CONCRETE 4 1/2" THICK
AVAILABLE OPTIONS * -----	THREE PHASE POWER, 480 VAC
	DRIVE THROUGH RAMPS
	RUNWAY LIGHTING (ETL APPROVED)
	RJ-50A ROLLING HYDRAULIC JACKING BEAM (ETL APPROVED)
	AIR LINES PLUMBED INTO TRACKS
	OIL DRAIN PAN
	20', 25' OR 30' TRACKS
	RUNWAY LIGHTING & OUTLETS (NON-ETL APPROVED)
	RJ-50, ROLLING HYDRAULIC JACKING BEAM (NON-ETL APPROVED)
	JP-50, ROLLING JACK PLATFORM (NON-ETL APPROVED)
	OBSTACLE SENSOR PACKAGE (NON-ETL APPROVED)

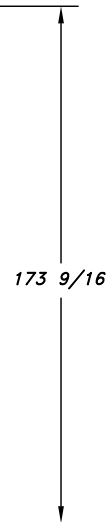

**NOTES: \***

- SOME OPTION COMBINATIONS ARE NOT AVAILABLE.
- SOME OPTION MAY INVALIDATE ANSI/ALI CERTIFICATION OF LIFT.

MOHAWK RESOURCES, LTD. RESERVES THE RIGHT TO MAKE CHANGES WITHOUT NOTICE.

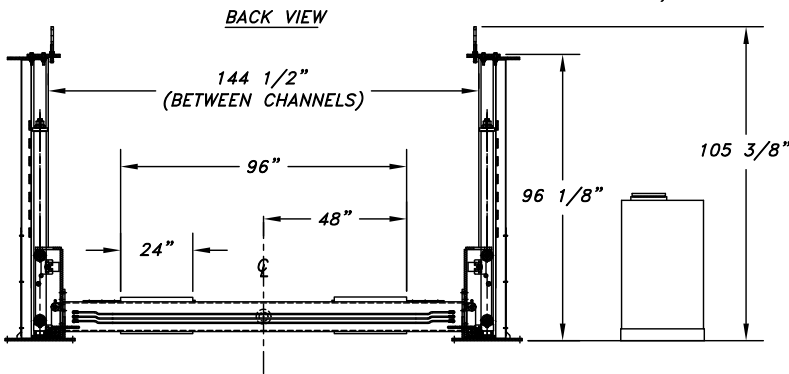

**MODEL TR-35  
30' TRACK**

4-POST TRACK LIFT  
CAPACITY: 35,000 LBS



THIS LIFT HAS BEEN TESTED AND CERTIFIED BY A NATIONALLY RECOGNIZED TESTING LABORATORY (NRTL) TO MEET THE REQUIREMENTS OF U.L. STANDARD 201 FOR GARAGE EQUIPMENT AND ANSI/ALI ALCTV-2006 FOR AUTOMOTIVE LIFT CONSTRUCTION.



**MOHAWK RESOURCES LTD.**

P.O. BOX 110  
65 VROOMAN AVENUE  
AMSTERDAM, NY 12010

PHN: (800) 833-2006  
IN NY: (518) 842-1431  
FAX: (518) 842-1289

<b>NOTES:</b> 1. REMOVE ALL SHARP CORNERS & EDGES. 2. UNLESS OTHERWISE SPECIFIED, SURFACE FINISH TO BE 125 RMS. 3. WELDING MEDIUM SHALL CONFORM TO AWS SPECIFICATIONS TO E-70XX ELECTRODES OR E-70TI CODE 5.3 FLUX CORE WIRE ONLY.	<b>TOLERANCES:</b> ANGULAR ± 1° FRACTIONAL ± .030 DECIMAL: 0.XX ± .030 0.XXX ± .005			SCALE NONE	DRAWN R.V.	<b>MOHAWK RESOURCES LTD.</b>	
		FILE NAME TR-35-30	NEXT ASSEMBLY	CHECKED	APPROVED	TITLE ILLUSTRATION & SPECS, TR-35 (30')	FROM
				DATE 4/08	WEIGHT 22000 LB.		△