

REV.	DESCRIPTION	DATE	BY	APP'D.
A	DIMENSIONAL ADJUSTMENTS MADE TO LIFT	3/00	dak	

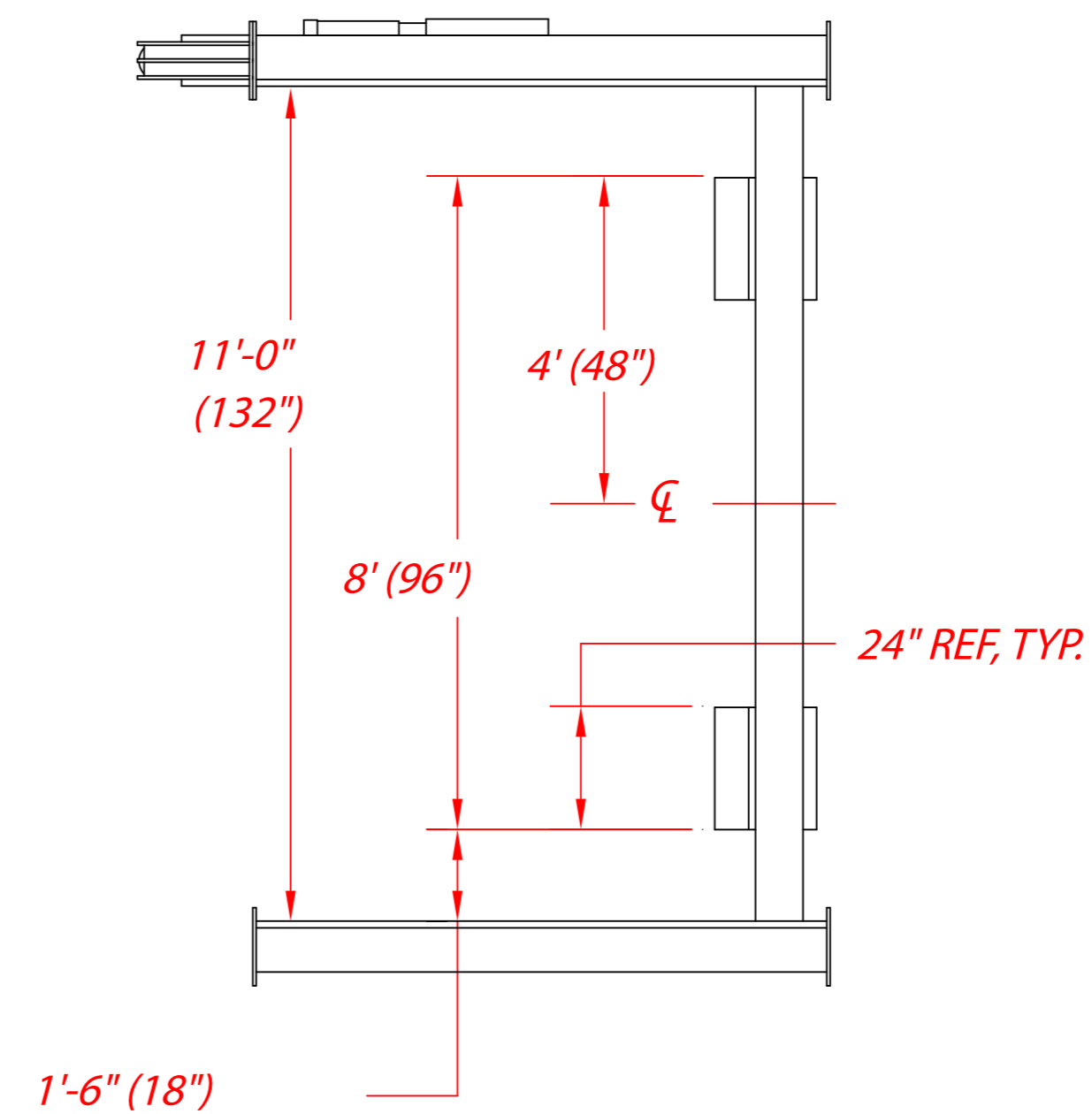

# MODEL TR-19

4-POST TRACK LIFT  
CAPACITY: 19,000 LBS

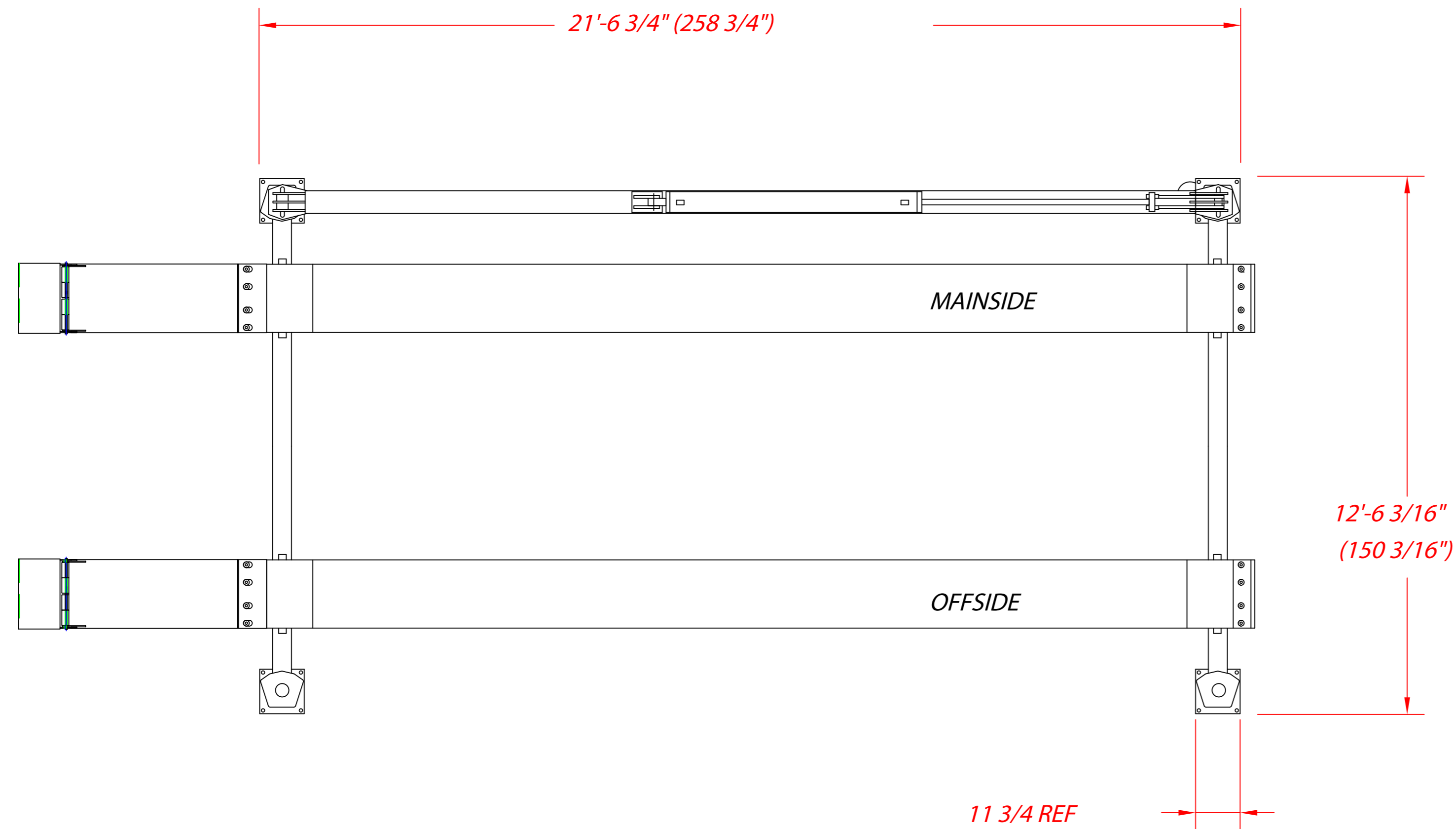
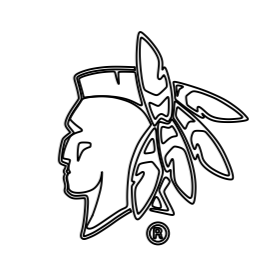

**MOHAWK RESOURCES LTD.**  
P.O. BOX 110  
65 VROOMAN AVENUE  
AMSTERDAM, NY 12010  
PHN: (800) 833-2006  
IN NY: (518) 842-1431  
FAX: (518) 842-1289

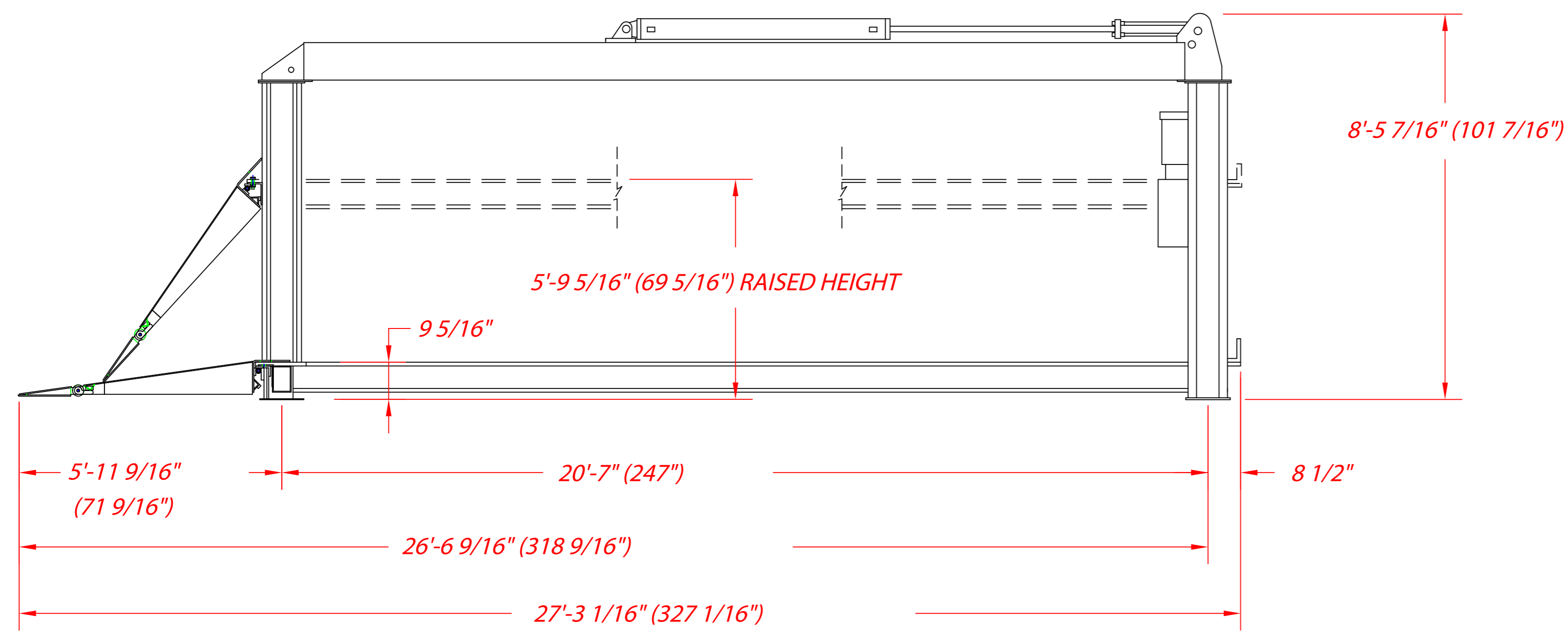

**SPECIFICATIONS:**

CAPACITY	-----	19,000 LB
LIFTING SPEED	-----	120 SECONDS
MOTOR RATING	-----	2 HP, 208-230 VAC SINGLE PHASE (3 PHASE OPTIONAL)
LIFTING MECHANISM	-----	5" HYDRAULIC CYLINDER ATTACHED TO (4) #646 LEAF CHAINS
OVERALL LENGTH	-----	27'-3 1/16"
OVERALL WIDTH	-----	12'-6 3/16"
LIFTING STROKE	-----	5"
TRACK WIDTH	-----	24"
CLEARANCE BETWEEN POSTS	-----	11'-0"
MECHANICAL SAFETY RELEASE	-----	SINGLE POINT
MECHANICAL SAFETY LOCKS	-----	ALL POSITION
BACK-UP HYDRAULIC SAFETY SYSTEMS	-----	P.C. FLOW CONTROLS & VELOCITY FUSES
WEIGHT	-----	5250 LB
AVAILABLE OPTIONS	-----	3 PHASE POWER FOR 208-230, OR 440-480 VAC @ 60 HZ
	-----	RJ-15, ROLLING HYDRAULIC JACKING BEAM
	-----	JP-15, ROLLING JACKING PLATFORM
	-----	OIL DRAIN PAN
	-----	DRIVE THROUGH RAMPS

SHOWN ABOVE WITH STANDARD 20' TRACKS  
NOTE: MOHAWK RESOURCES, LTD. RESERVES THE RIGHT TO MAKE CHANGES WITHOUT NOTICE.

**NOTICE OF CONFIDENTIAL INFORMATION**

INFORMATION CONTAINED HEREIN IS CONFIDENTIAL AND PROPERTY OF MOHAWK RESOURCES LTD. WHERE DRAWING IS FURNISHED TO OTHERS IT SHALL BE USED SOLELY FOR PURPOSES OF INSPECTION, INSTALLATION, OR MAINTENANCE. THE INFORMATION SHALL NOT BE USED OR DISCLOSED BY THE RECIPIENT FOR ANY OTHER PURPOSES WHATSOEVER.

**NOTES:**

- REMOVE ALL SHARP CORNERS & EDGES.
- UNLESS OTHERWISE SPECIFIED, SURFACE FINISH TO BE 125 RMS.
- WELDING MEDIUM SHALL CONFORM TO AWS SPECIFICATIONS TO E-70XX ELECTRODES OR E-70TI CODE 5.3 FLUX CORE WIRE ONLY.

**TOLERANCES:**

ANGULAR: ± 1 °  
FRACTIONAL: ± .030  
DECIMAL: 0.XX ± .030  
0.XXX ± .005

FILE NAME: TR-19

SCALE: NONE  
DRAWN: R.V.  
CHECKED: APPROVED  
DATE: 3/00  
WEIGHT: 5250 LB.

**MOHAWK RESOURCES LTD.**

TITLE: ILLUSTRATION & SPECS, TR-19

FROM: DRAWING NUMBER: TR-19