

REV.	DESCRIPTION	DATE	BY	APP'D.
A	DIMENSIONAL ADJUSTMENTS MADE TO LIFT	3/00	dak	

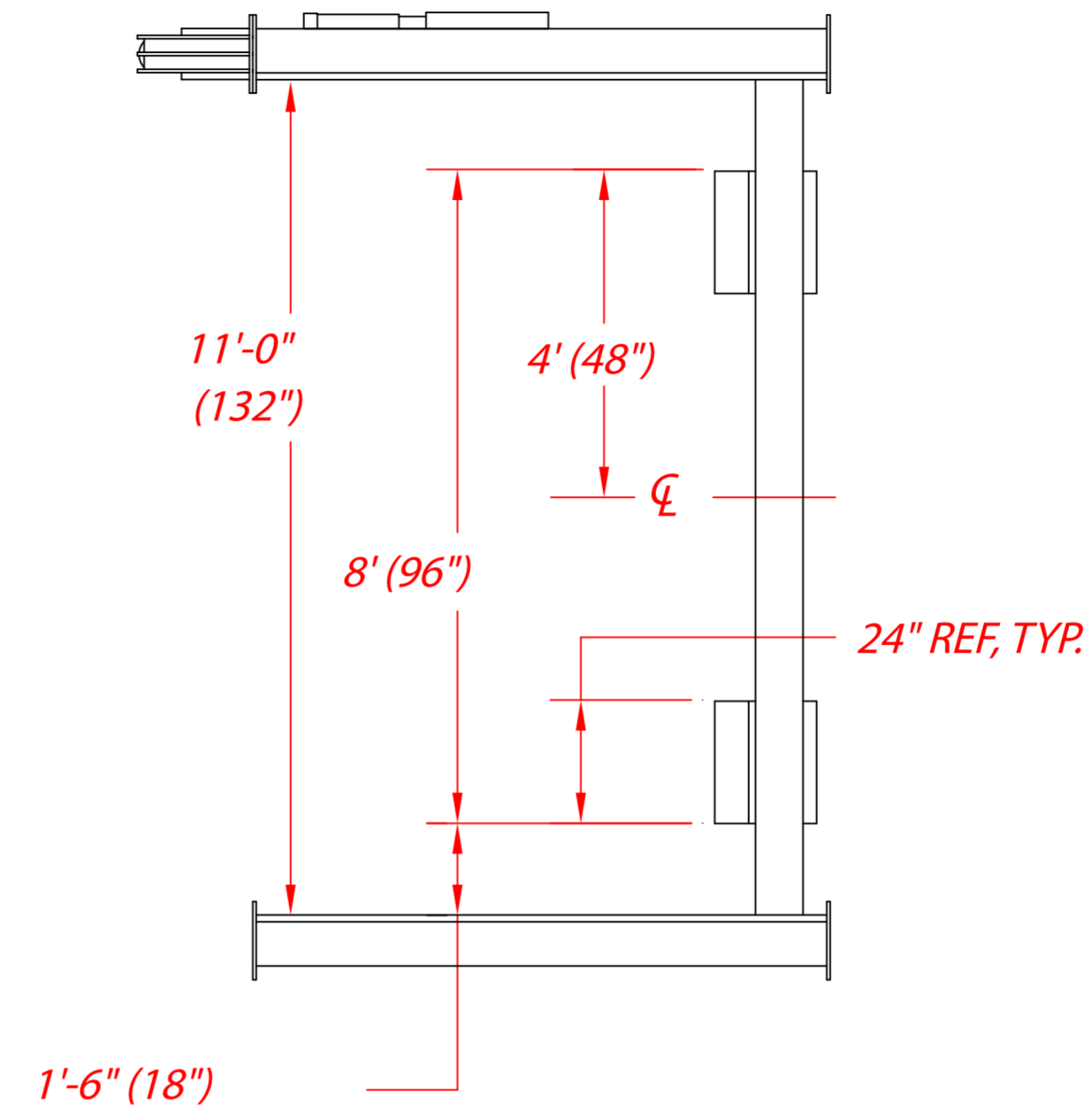
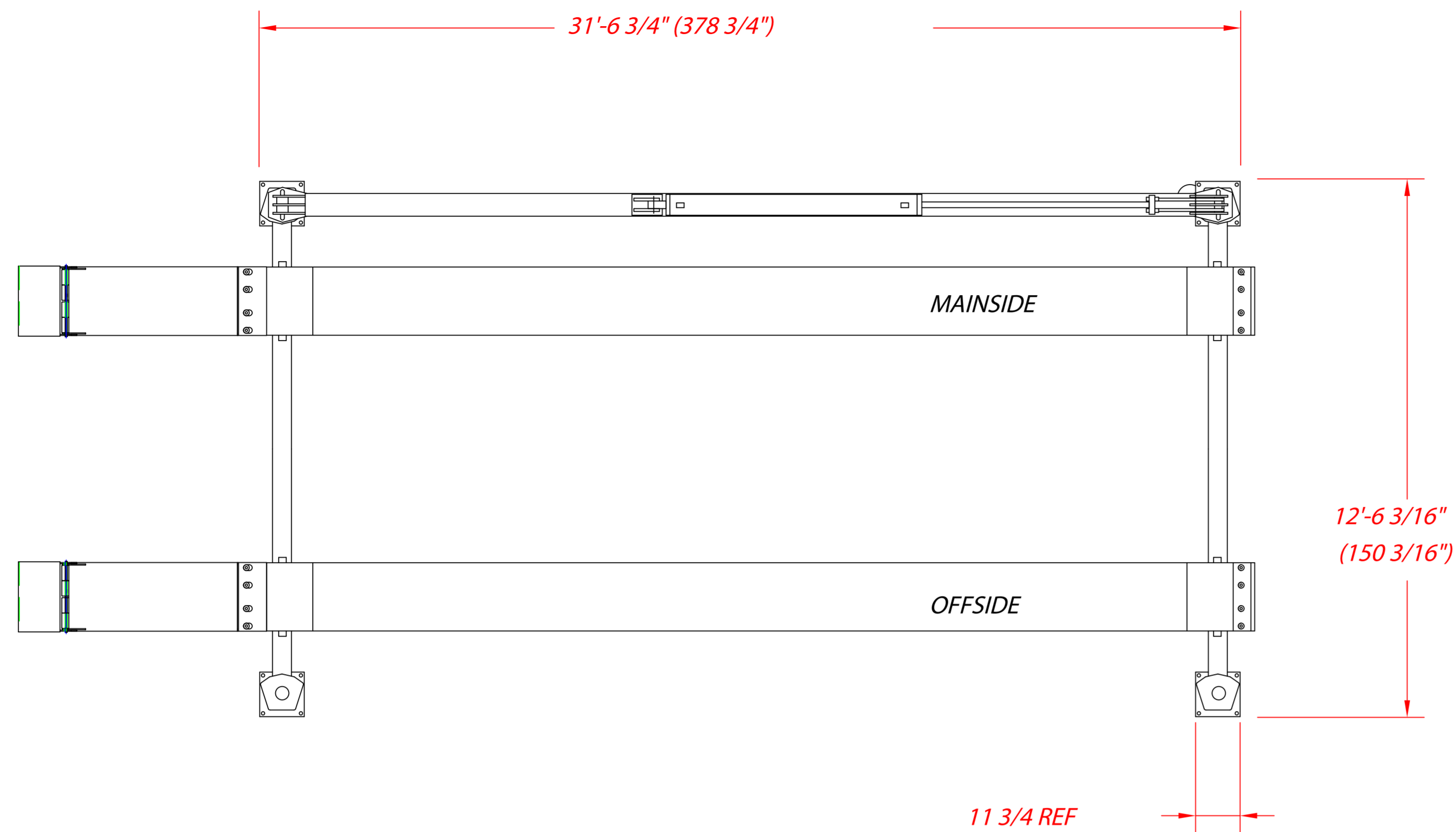

MODEL TR-25A

4-POST TRACK LIFT
CAPACITY: 25,000 LBS
SHOWN WITH 30' TRACKS

MOHAWK RESOURCES LTD.
P.O. BOX 110
65 VROOMAN AVENUE
AMSTERDAM, NY 12010
PHN: (800) 833-2006
IN NY: (518) 842-1431
FAX: (518) 842-1289

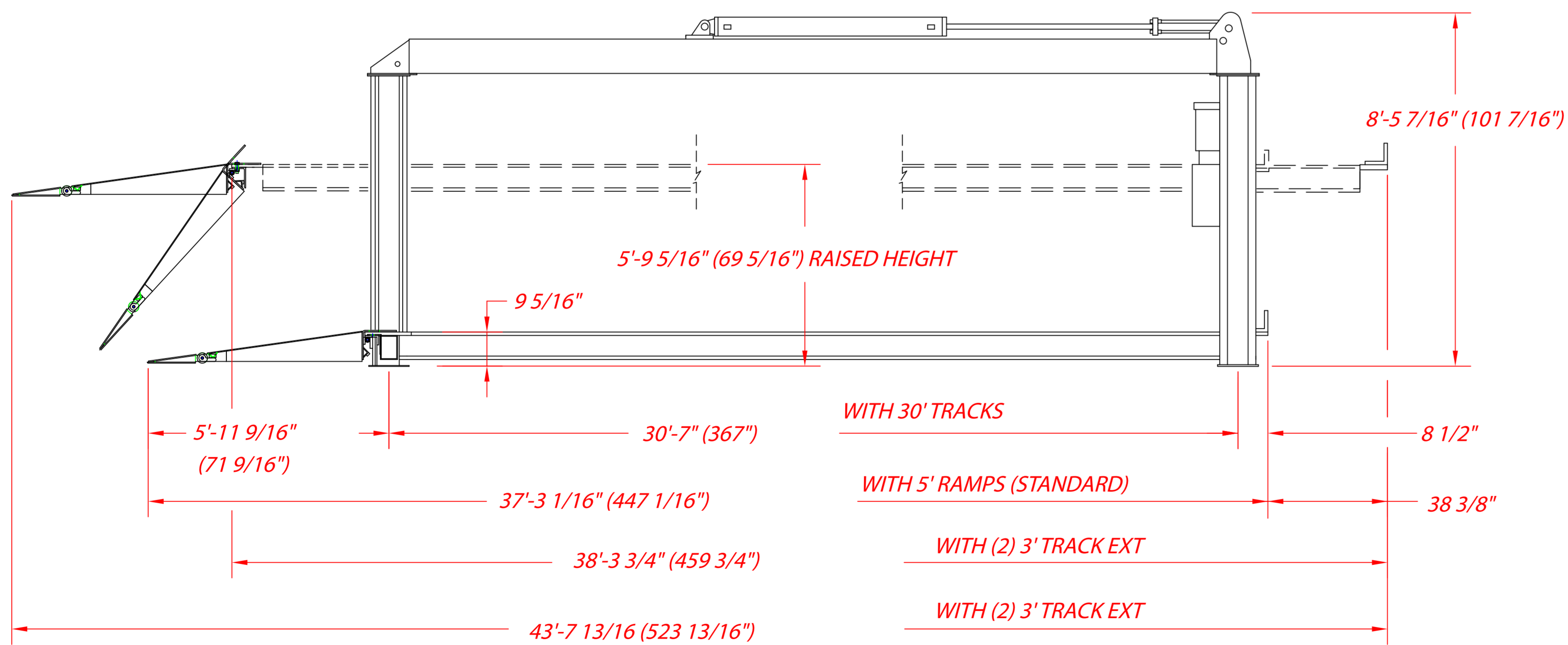

SPECIFICATIONS:

CAPACITY	25,000 LB
LIFTING SPEED	120 SECONDS
MOTOR RATING	2 HP, 208-230 VAC SINGLE PHASE (3 PHASE OPTIONAL)
LIFTING MECHANISM	5" HYDRAULIC CYLINDER ATTACHED TO (4) #646 LEAF CHAINS
OVERALL LENGTH	37'-3 1/16"
OVERALL WIDTH	12'-6 3/16"
LIFTING STROKE	5'
TRACK WIDTH	24"
CLEARANCE BETWEEN POSTS	11'-0"
MECHANICAL SAFETY RELEASE	SINGLE POINT
MECHANICAL SAFETY LOCKS	ALL POSITION
BACK-UP HYDRAULIC SAFETY SYSTEMS	P.C. FLOW CONTROLS & VELOCITY FUSES
WEIGHT	6100 LB
AVAILABLE OPTIONS	3' TRACK EXTENSIONS (FRONT, REAR, OR BOTH)
	3 PHASE POWER FOR 208-230, 460, & 575 VAC @ 60 HZ
	ALIGNMENT PACKAGE
	RJ-25, ROLLING HYDRAULIC JACKING BEAM
	JP-25, ROLLING JACKING PLATFORM
	RJ-15, ROLLING HYDRAULIC JACKING BEAM
	JP-15, ROLLING JACKING PLATFORM
	115 VAC DUPLEX OUTLET AT POWER UNIT
	ELECTRIC SOLENOID DOWN VALVE
	RUNWAY LIGHTING
	OIL DRAIN PAN
	OBSTACLE SENSOR PACKAGE
	LOCKABLE MAIN SWITCH
	AUDIBLE DESCENT WARNING
	20', 25', & 30' TRACKS
	DRIVE THROUGH RAMPS

SHOWN ABOVE WITH 30' TRACKS
NOTE: MOHAWK RESOURCES, LTD. RESERVES THE RIGHT TO MAKE CHANGES WITHOUT NOTICE.

NOTICE OF CONFIDENTIAL INFORMATION

INFORMATION CONTAINED HEREIN IS CONFIDENTIAL AND PROPERTY OF MOHAWK RESOURCES LTD. WHERE DRAWING IS FURNISHED TO OTHERS IT SHALL BE USED SOLELY FOR PURPOSES OF INSPECTION, INSTALLATION, OR MAINTENANCE. THE INFORMATION SHALL NOT BE USED OR DISCLOSED BY THE RECIPIENT FOR ANY OTHER PURPOSES WHATSOEVER.

NOTES:

- REMOVE ALL SHARP CORNERS & EDGES.
- UNLESS OTHERWISE SPECIFIED, SURFACE FINISH TO BE 125 RMS.
- WELDING MEDIUM SHALL CONFORM TO AWS SPECIFICATIONS TO E-70XX ELECTRODES OR E-70TI CODE 5.3 FLUX CORE WIRE ONLY.

TOLERANCES:	
ANGULAR	± 1 °
FRACTIONAL	± .030
DECIMAL:	
0.XX	± .030
0.XXX	± .005
FILE NAME	TR-25-30
NEXT ASSEMBLY	

SCALE	NONE	DRAWN	R.V.	MOHAWK RESOURCES LTD.
CHECKED		APPROVED		TITLE
DATE	3/00	WEIGHT	6100 LB.	ILLUSTRATION & SPECS, TR-25A, (30')
FROM		DRAWING NUMBER	TR-25-30	

D-SIZE

