

REV.	DESCRIPTION	DATE	BY	APP'D.
E	ALI VERIFICATION LOGO CHANGED	12/15	CHS	

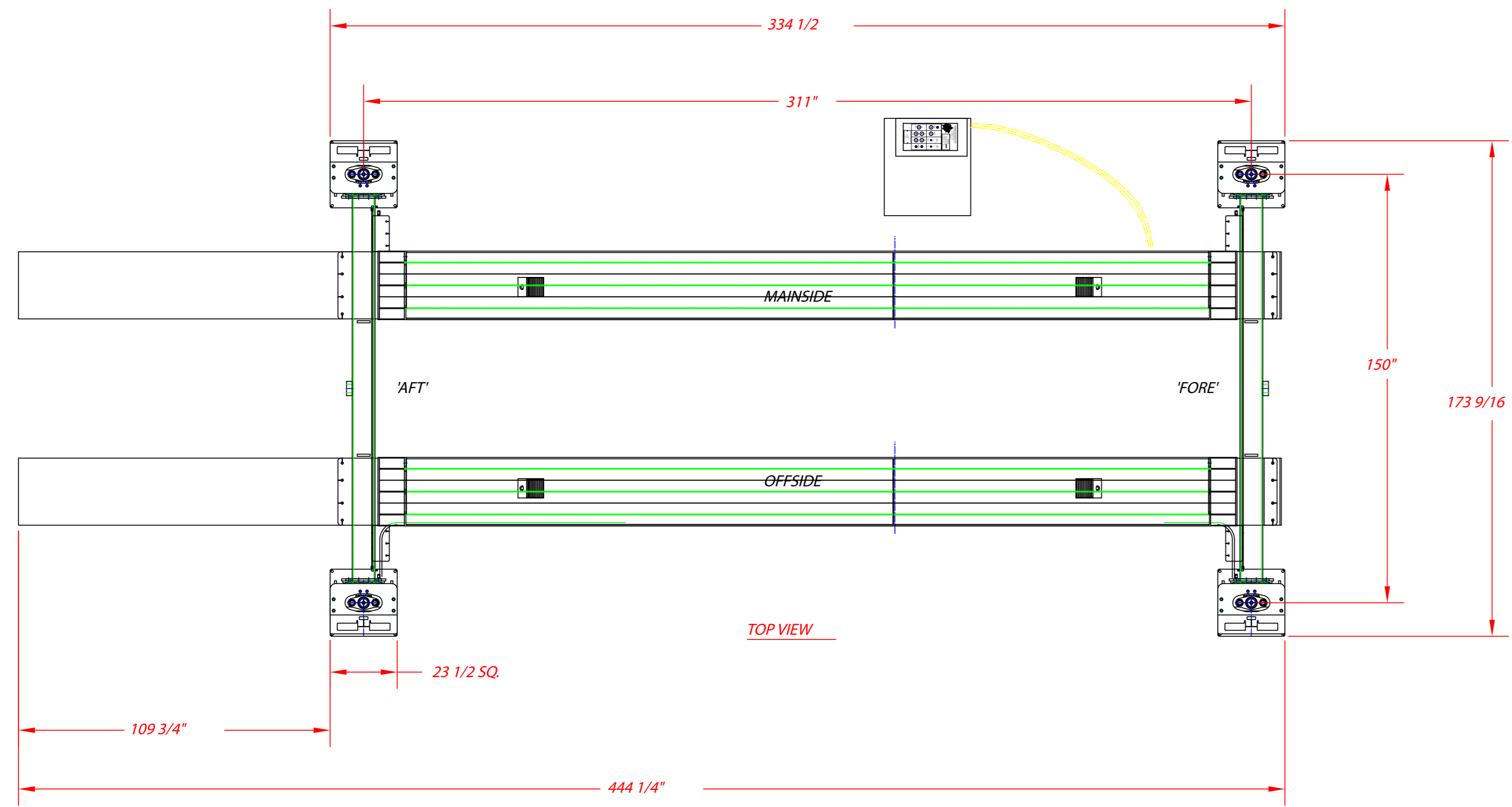

SPECIFICATIONS:

CAPACITY	50,000 LB
LIFTING SPEED	120 SECONDS
MOTOR RATING	10 HP, 208-230 VAC THREE PHASE
LIFTING MECHANISM	(4) 4" HYDRAULIC CYLINDERS, DIRECT DRIVE
OVERALL LENGTH	37'-0 1/4"
OVERALL WIDTH	14'-5 9/16"
LIFTING STROKE	5'
TRACK WIDTH	24"
CLEARANCE BETWEEN POSTS	11'-8"
MECHANICAL SAFETY RELEASE	SINGLE POINT
MECHANICAL SAFETY LOCKS	MULTI-POSITION
BACK-UP HYDRAULIC SAFETY SYSTEMS	P.C. FLOW CONTROLS & VELOCITY FUSES
WEIGHT	17000 LB
SYNCHRONIZATION (MAIN TO OFFSIDE)	(4) #646 LEAF CHAINS
SYNCHRONIZATION (FORE TO AFT)	ELECTRICALLY AUTOMATIC / MANUALLY ADJUSTABLE
FLOOR REQUIREMENTS	4000 PSI CONCRETE 4 1/2" THICK
AVAILABLE OPTIONS *	THREE PHASE POWER, 480 VAC
	DRIVE THROUGH RAMPS
	RUNWAY LIGHTING (ETL APPROVED)
	RJ-50A ROLLING HYDRAULIC JACKING BEAM (ETL APPROVED)
	AIR LINES PLUMBED INTO TRACKS
	OIL DRAIN PAN
	20', 25' OR 30' TRACKS
	RUNWAY LIGHTING & OUTLETS (NON-ETL APPROVED)
	RJ-50, ROLLING HYDRAULIC JACKING BEAM (NON-ETL APPROVED)
	JP-50, ROLLING JACK PLATFORM (NON-ETL APPROVED)
	OBSTACLE SENSOR PACKAGE (NON-ETL APPROVED)

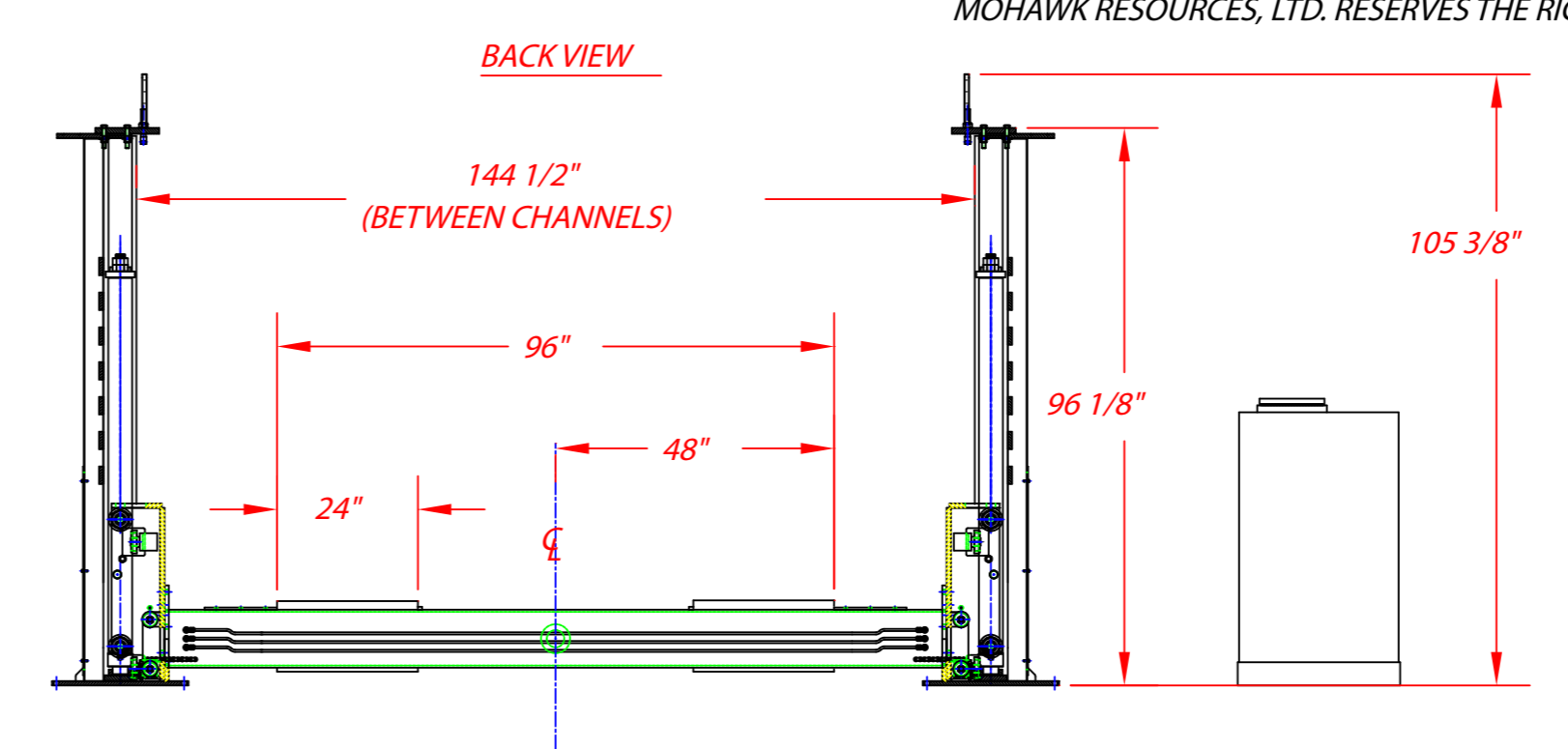
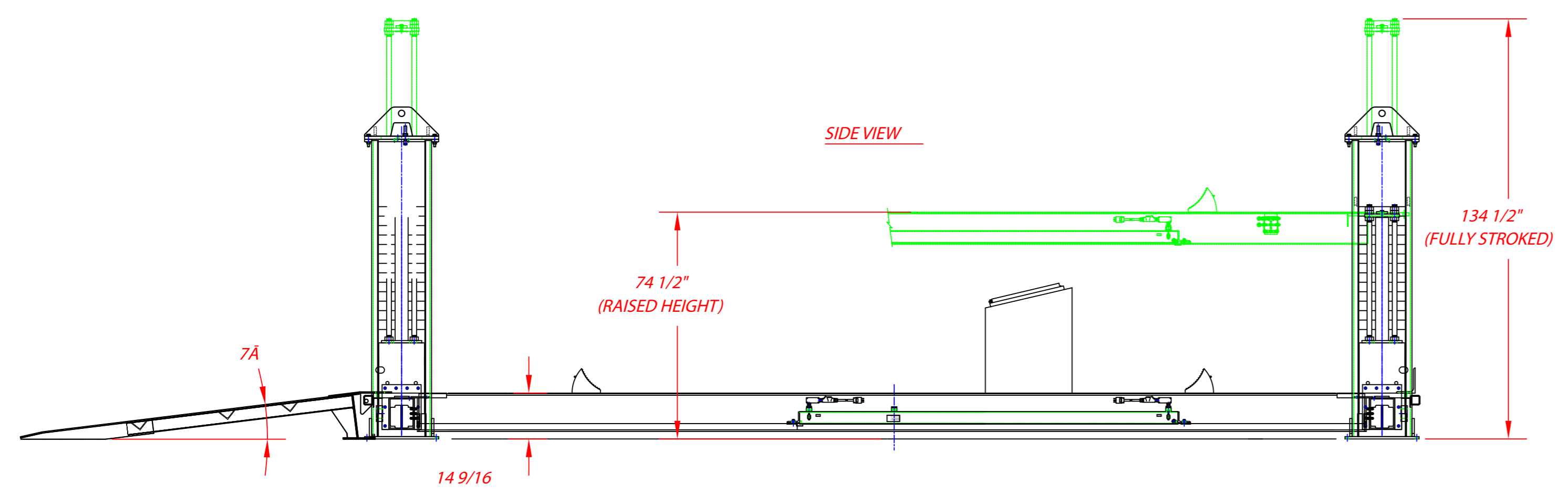

NOTES: *
 1. SOME OPTION COMBINATIONS ARE NOT AVAILABLE.
 2. SOME OPTION MAY INVALIDATE ANSI/ALI CERTIFICATION OF LIFT.

MOHAWK RESOURCES, LTD. RESERVES THE RIGHT TO MAKE CHANGES WITHOUT NOTICE.

**MODEL TR-50
25' TRACK**

4-POST TRACK LIFT
CAPACITY: 50,000 LBS



THIS LIFT HAS BEEN TESTED AND CERTIFIED BY A NATIONALLY RECOGNIZED TESTING LABORATORY (NRTL) TO MEET THE REQUIREMENTS OF U.L. STANDARD 201 FOR GARAGE EQUIPMENT AND ANSI/ALI ALCTV-2011 FOR AUTOMOTIVE LIFT CONSTRUCTION.

* SHOWN WITH 25' RUNWAYS.

** POWER UNIT LOCATION PER CUSTOMER'S SPECIFICATION.
SHOWN ABOVE IN STANDARD LOCATION.

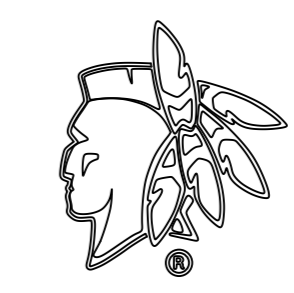

MOHAWK RESOURCES LTD.
 P.O. BOX 110
 65 VROOMAN AVENUE
 AMSTERDAM, NY 12010
 PHN: (800) 833-2006
 IN NY: (518) 842-1431
 FAX: (518) 842-1289

NOTICE OF CONFIDENTIAL INFORMATION
 INFORMATION CONTAINED HEREIN IS CONFIDENTIAL AND PROPERTY OF MOHAWK RESOURCES LTD.. WHERE DRAWING IS FURNISHED TO OTHERS IT SHALL BE USED SOLELY FOR PURPOSES OF INSPECTION, INSTALLATION, OR MAINTENANCE. THE INFORMATION SHALL NOT BE USED OR DISCLOSED BY THE RECIPIENT FOR ANY OTHER PURPOSES WHATSOEVER.

NOTES:
 1. REMOVE ALL SHARP CORNERS & EDGES.
 2. UNLESS OTHERWISE SPECIFIED, SURFACE FINISH TO BE 125 RMS.
 3. WELDING MEDIUM SHALL CONFORM TO AWS SPECIFICATIONS TO E-70XX ELECTRODES OR E-70T1 CODE 5.3 FLUX CORE WIRE ONLY.

TOLERANCES:
 ANGULAR: ± 1 °
 FRACTIONAL: ± .030
 DECIMAL: ± .030
 0.XX: ± .005
 0.XXX: ± .005

SCALE: NONE
 DRAWN: R.V.
 CHECKED: APPROVED
 DATE: 4/08
 WEIGHT: 17000 LB.

MOHAWK RESOURCES LTD.	
TITLE: ILLUSTRATION & SPECS, TR-50 (25')	FROM: DRAWING NUMBER: TR-50-25